

"PC" Flanged Roller End Bearings

These bearings are lightweight, economical, low noise conveyor roller bearings which exhibit superior load carrying capabilities, compared with conventional equivalents.



The bearings are also free running being assembled with a plastic ball retainer, and lubricated with a high performance fully synthetic gear lubricant.

Standard recommended operating temperature range -8° to $+60^{\circ}$ C.

Standard finish is zinc plated.

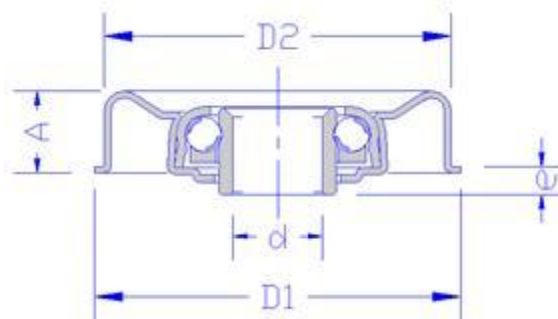

Part Number	D1	D2	d dia	d hex	A	e	Tube Size	Dynamic Load (kgs)
GF35PC	36.95	35.20	8mm : 10mm :12mm : 7/16	8mm : 11mm	10.00	3.50	1 1/2 x 16/18 SWG	50
GF37PC	39.80	37.20	8mm : 10mm :12mm : 7/16	8mm : 11mm	10.00	3.70	40 x 1.5	50
GF46PC	49.30	46.30	8mm : 10mm :12mm : 7/16	8mm : 11mm	11.00	3.70	50 x 2.0	50

GF47PC	49.80	47.20	8mm : 10mm :12mm : 7/16	8mm : 11mm	11.00	3.70	50 x 1.5	50
GF52PC	54.90	52.90	8mm : 10mm :12mm : 7/16	8mm : 11mm	12.00	3.70	2 1/4 x 14 SWG	50
GF56PC	59.20	56.10	8mm : 10mm :12mm : 7/16	8mm : 11mm	12.70	3.70	60 x 2.0	50
GF57PC	59.40	57.30	8mm : 10mm :12mm : 7/16	8mm : 11mm	12.70	3.70	60 x 1.5	50
GF76PC	79.50	76.30	8mm : 10mm :12mm : 7/16	8mm : 11mm	13.70	3.70	80 x 2.0	50