

## Un-Flanged Roller End Bearings

Inner and outer raceways are made from case hardened steel.

Standard finish is self colour, suffix with a "Z" if Zinc plating is required.

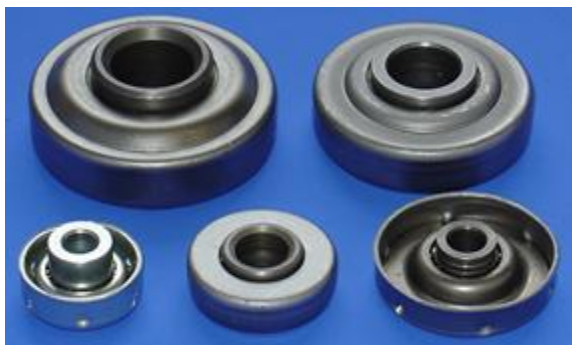

Heavy duty bearings are normally greased as standard.

Light duty bearings are normally oiled as standard.

Heavy duty bearings are protected from particle ingress by the inclusion of a felt seal.

Un-Flanged bearings should be an interference fit and further retained by welding.

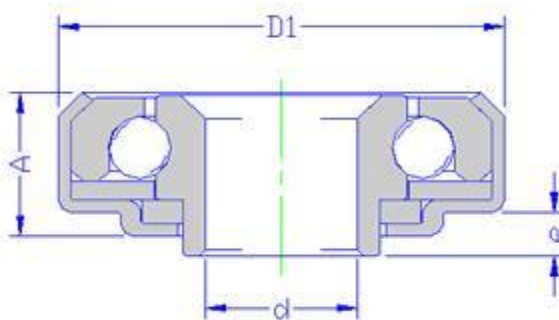

Part Number	D1	d dia	d hex	A	e	Tube Size	Dynamic Load (kgs)
<b>3G916</b>	2.128"	7/16"	-	1/2"	1/8	2 1/4" x 16 SWG	20
<b>HG610</b>	1.260"	7/16" : 1/2"	11mm	7/16"	3/16"	1 1/2" x 10 SWG	40
<b>HG810</b>	1.744"	7/16" : 1/2" : 5/8"	11mm	9/16"	1/8"	2" x 10 SWG	40
<b>HG1208</b>	2.680"	3/4" : 7/8" : 1"	-	7/8"	5/16"	3" x 8 SWG	250
<b>HG1210</b>	2.744"	5/8" : 3/4"	-	13/16"	5/16"	3" x 10 SWG	200
<b>HG1403</b>	3.010"	1" : 1 1/4"	-	1"	7/16"	3 1/2" x 3 SWG	450